

## Cobra Series

### D38999/11-35 Active Optoelectronic Cable Adapter, Electrical Interface, Ethernet, Fibre Channel and sFPDP

Single Duplex Port, Right Angle

#### FEATURES

- Suitable for Fast Ethernet, Gigabit Ethernet, 1x/2xFibre Channel and sFPDP applications from 50Mbps to 3.2Gbps
- Maximum optical channel bit error rate less than  $1 \times 10^{-12}$
- Operating temperature range from  $-55^{\circ}\text{C}$  to  $+85^{\circ}\text{C}$
- Shock and vibration resistant per RTCA / D0-160E
- Rugged tight buffered fibers are strengthened with aramid yarn and jacketed with water, sunlight, chemical and abrasion-resistant polyurethane
- All dielectric rodent-resistant cables handles like any other tactical cable, yet it offers extra protection against rodent attack
- Standard thirteen pin electrical interface per MIL-STD-1560
- Tactical fiber optic cable with heavy duty cable strain relief at each end of the assembly
- Intermateable with MIL-DTL-38999 size 11-35 receptacle connectors

#### APPLICATIONS

Cobra series D38999 size 11-35 active optoelectronic cable adapters enable high speed network communications over long distances in harsh environments.

- Fast or Gigabit Ethernet switches and peripherals
- Fibre Channel switches and peripherals
- ARINC 818 video interfaces
- sFPDP data links

Cobra series D38999 size 11-35 active optoelectronic cable adapters provide a rugged cylindrical interface for transporting high speed electrical signals over fiber optic cable with rugged, high mating cycle electrical disconnects at each end.

The multimode optical fiber cable supports applications where copper cable link distance, bandwidth, weight or bulk make the use of twisted pair, twinax or quadax copper conductors unacceptable.



One Duplex Channel Operating from 50Mbps to 3.2Gbps

#### DESCRIPTION

Cobra series D38999 size 11-35 media interface adapter cables consist of optoelectronic transmitter and receiver functions integrated into a right angle D38999 cable backshell. The optical transmitters are 850nm VCSEL lasers. The transmitter input lines are driven with differential CML signals applied to the transmitter (TX+ and TX-) lines.

The optical receivers consist of PIN and preamplifier assemblies and limiting post-amplifiers. Outputs from the receivers consist of differential CML data signals on the receiver (RX+ and RX-) lines and single ended CMOS indicator functions on the Loss of Signal (LOS) lines. The receiver data lines are squelched upon LOS assertion, preventing errant data generation when an invalid incoming optical signal is presented to the receiver.

The electrical mating interface of the Cobra series media interface adapter cables is a MIL-DTL-38999 size 11-35 cable plug per MIL-STD-1560.

Cobra series D38999 size 11-35 media interface adapter cables are vibration isolated, environmentally hardened components designed for use in harsh environment applications.



#### ORDERING INFORMATION

Application	Part Number
-------------	-------------

See Appendix A1 and A2 for part number options

# Facilitating Secure Communications in Harsh Environments

Cobra Series D38999/11-35 Active Optoelectronic Cable Adapter,  
Multimode, 850nm, ARINC 664, 818, 803 & 804 Compliant

## ABSOLUTE MAXIMUM RATINGS

Absolute maximum limits mean that no catastrophic damage will occur if the product is subjected to these ratings for short periods, provided each limiting parameter is in isolation and all other parameters have values within the performance specification. It should not be assumed that limiting values of more than one parameter can be applied to the product at the same time.

Parameter	Symbol	Minimum	Typical	Maximum	Unit
Storage Temperature	$T_s$	-65		+100	°C
Supply Voltage	$V_{CC}$	-0.5		+4.5	V
RX Output Current	$I_o$			50	mA
Differential Input Voltage (p-p)	$V_D$			2.2	V
Cable Tensile Strength	Lbs <sub>f</sub>	300			lbs
Cable Operating Bend Radius	$R_B$	1.8			cm

## RECOMMENDED OPERATING CONDITIONS

Parameter	Symbol	Minimum	Typical	Maximum	Unit
Operating Temperature	$T_A$	-55		+85	°C
Power Supply Voltage	$V_{CC}$	+3.135		+3.465	V
TX Common Mode Voltage	$V_{CM}$			2.0	V
TX Differential Input Voltage (p-p)	$V_D$	0.25		2.2	V
Power Supply Noise (p-p)	$N_P$			200	mV

## SPECIFICATIONS COMPLIANCE

Requirement	Feature	Condition	Notes
RTCA / D0-160E	ESD	Class II	2200V
RTCA / D0-160E	Vibration	3.8g <sup>2</sup> /Hz	43G rms
RTCA / D0-160E	Shock	40.0g	6-9mS
RTCA / D0-160E	Flame Resistance	Method 1012	30 Seconds
RTCA / D0-160E	Damp Heat	10 Cycles	24 Hours
EIA-455-41 MIL	Crush Resistant	440 N/cm	
EIA-455-25 MIL	Impact Resistance	200 impacts	
EIA-455-104 MIL	Cyclic Flexing Test	2000 cycles	

## MATERIALS

Item	Detail	Notes
38999 Shell & Backshell	Aluminum	
38999 Shell Plating	Olive Drab Cadmium over Nickel	QQ-P-416, QQ-N-290
Insert	Silicone Elastomer	

# Facilitating Secure Communications in Harsh Environments

Cobra Series D38999/11-35 Active Optoelectronic Cable Adapter,  
Multimode, 850nm, ARINC 664, 818, 803 & 804 Compliant

## ELECTRICAL TRANSMITTERS $T_A$ = Operating Temperature Range, $V_{CC}$ = 3.135V to 3.465V

Parameter	Symbol	Minimum	Typical	Maximum	Unit
Output Differential Voltage Level	$V_{OD}$	550	620	725	mV <sub>P-P</sub>
Output Common-Mode Voltage	$V_{OCM}$	$V_{CC}-0.2$		$V_{CC}-0.1$	V

## ELECTRICAL RECEIVERS $T_A$ = Operating Temperature Range, $V_{CC}$ = 3.135V to 3.465V

Parameter	Symbol	Minimum	Typical	Maximum	Unit
Input Differential Voltage Level	$V_{OD}$	400		1600	mV <sub>P-P</sub>
Input Common-Mode Voltage	$V_{ICMDC}$	$V_{CC}-0.8$		$V_{CC}-0.2$	V

## POWER SUPPLY CURRENT $T_A$ = Operating Temperature Range, $V_{CC}$ = 3.135V to 3.465V

Parameter	Symbol	Minimum	Typical	Maximum	Unit
Supply Current	$I_{CCT}$		165	190	mA

# Facilitating Secure Communications in Harsh Environments

Cobra Series D38999/11-35 Active Optoelectronic Cable Adapter,  
Multimode, 850nm, ARINC 664, 818, 803 & 804 Compliant

## OUTLINE DRAWING

Dimensions are shown as: inches [mm]

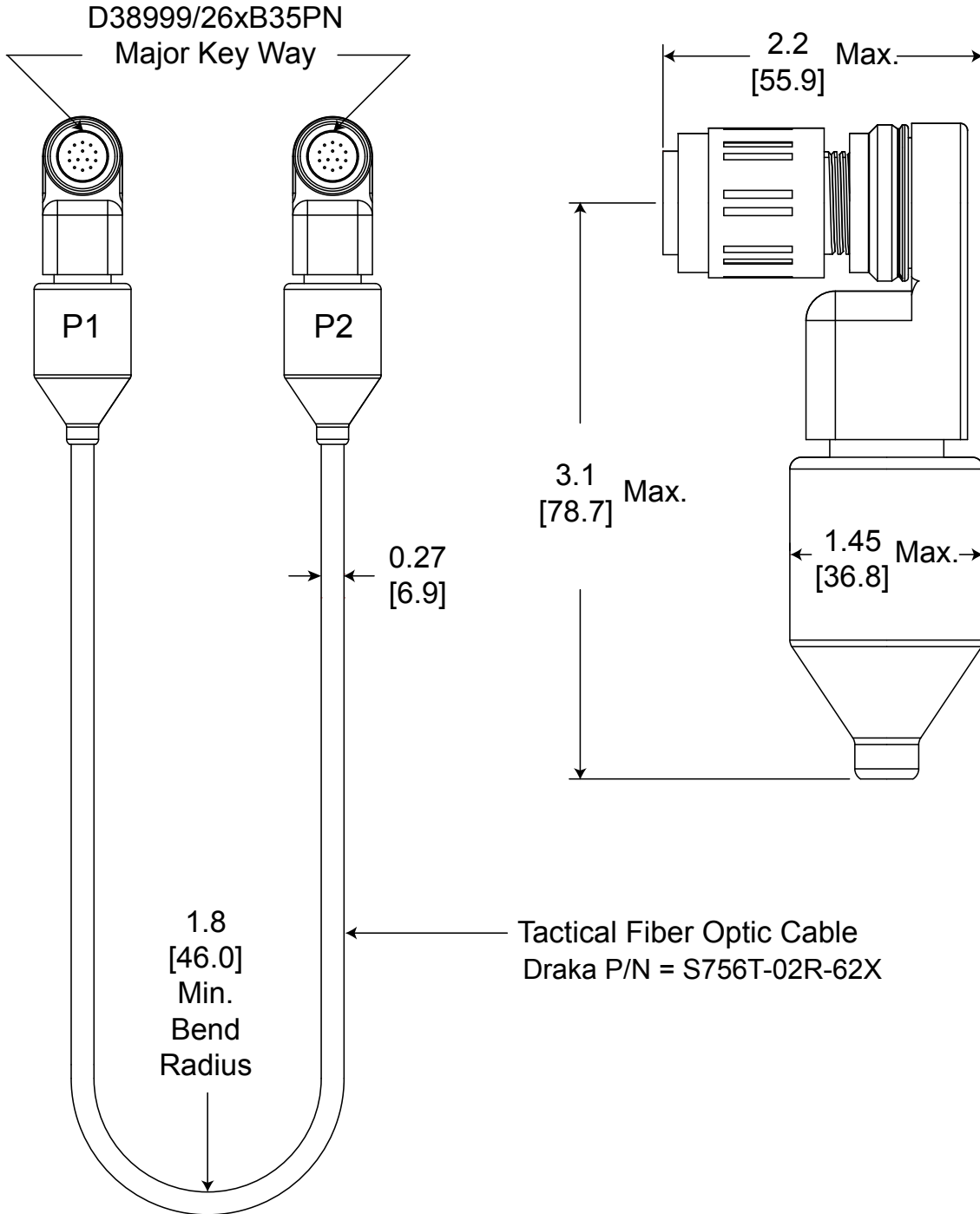

P/N = C35P-2S1E-Bx-Lxx

xx = 01, 03, 05, 10, 25 and 50 meters

See Appendix A1 for more options

**MOOG**  
PROTOKRAFT

C35P-2S1E-Bx-Lxxx-DS - December 17, 2012 - Released

# Facilitating Secure Communications in Harsh Environments

Cobra Series D38999/11-35 Active Optoelectronic Cable Adapter,  
Multimode, 850nm, ARINC 664, 818, 803 & 804 Compliant

## MEDIA INTERFACE ADAPTER INSERT ARRANGEMENT

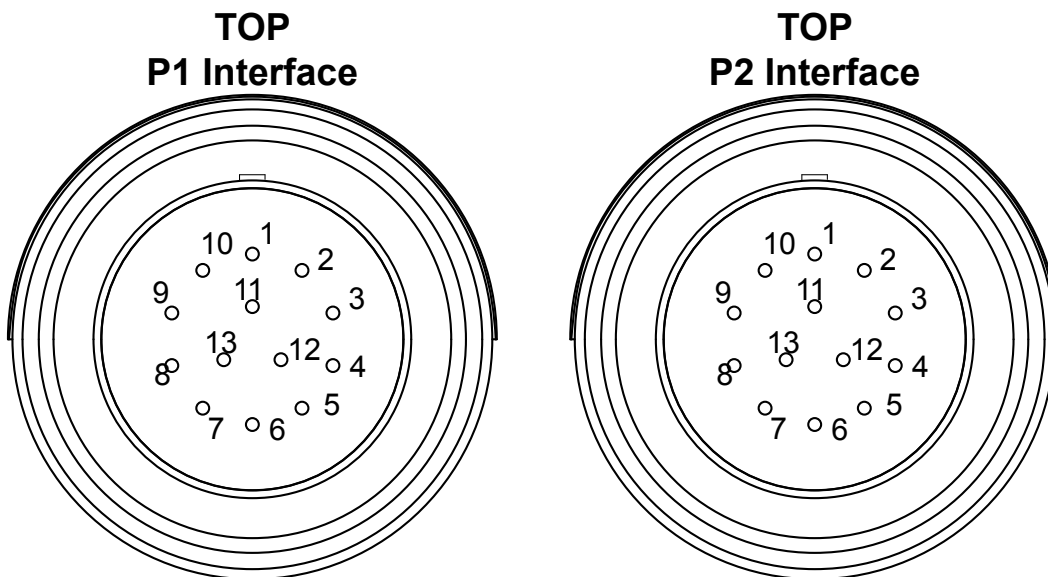

Front faces of the P1 / P2 media interface adapter insert shown, mating connector receptacle opposite - see Electrical Pin Assignment chart for details

## ELECTRICAL PIN ASSIGNMENTS

Pin Number	Symbol	Description	Logic Family
1	GND	Ground	N/A
2	TX_DIS	TX Disable - Input Logic 1: Disable Optical Output Logic 0: Enable Optical Output	CMOS (Internal 4.7KΩ to 10.0KΩ pullup)
3	TX+	Transmitter Data - Input	CML
4	TX-	Transmitter Data - Input	CML
5	GND	Ground	N/A
6	V <sub>cc</sub>	3.3VDC Power Supply +/-5%	N/A
7	V <sub>cc</sub>	3.3VDC Power Supply +/-5%	N/A
8	RX+	Receiver Data - Output	CML
9	RX-	Receiver Data - Output	CML
10	LOS	Loss of Signal - Output Satisfactory Optical Input: Logic "0" Output Unsatisfactory Optical Input: Logic "1" Output	Open Drain CMOS
11	GND	Ground	N/A
12	GND	Ground	N/A
13	GND	Ground	N/A

Cobra Series D38999/11-35 Active Optoelectronic Cable Adapter,  
Multimode, 850nm, ARINC 664, 818, 803 & 804 Compliant

## Application Guide Thunder and Cobra

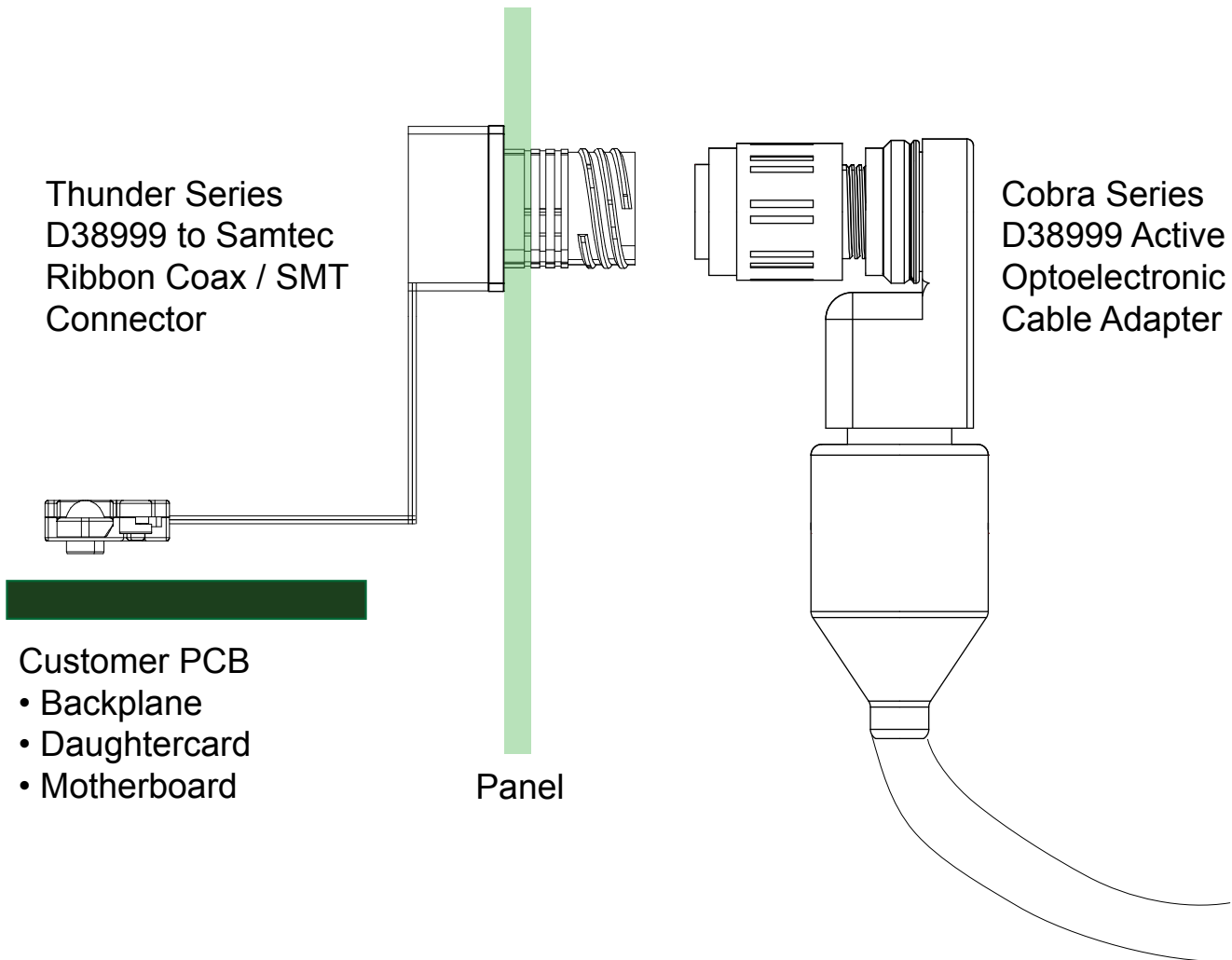

**P/N = C38x-3513-Bx-Lxxx**  
**See page 7 for more details**

**P/N = C35P-2S1E-Bx-Lxx**  
**See page 3 for more details**

# Facilitating Secure Communications in Harsh Environments

Cobra Series D38999/11-35 Active Optoelectronic Cable Adapter,  
Multimode, 850nm, ARINC 664, 818, 803 & 804 Compliant

## OUTLINE DRAWING

### Flange Mount Option

Dimensions are shown as: inches [mm]

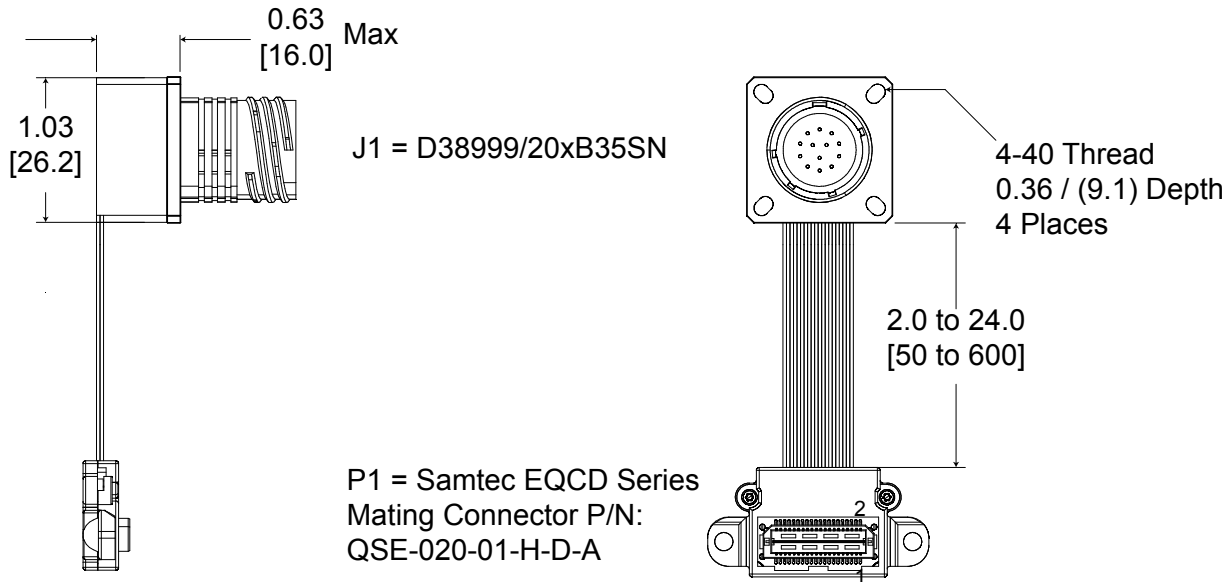

## Panel Cutout Dimensions

Rear Panel Mounting Only

Shell Size Code	Shell Size	M Min	P Holes	R Bsc
B	11	0.812 (20.62)	0.133 (3.4) 0.123 (3.1)	0.812 (20.62)

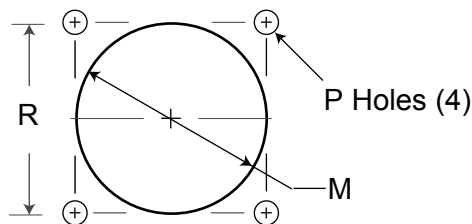

Part Number = \*C38F-3513-Bx-Lxxx

\*see page 8 for part number / cable length options and Appendix A2 for complete ordering options

**MOOG**  
PROTOKRAFT

C35P-2S1E-Bx-Lxxx-DS - December 17, 2012 - Released

Cobra Series D38999/11-35 Active Optoelectronic Cable Adapter,  
Multimode, 850nm, ARINC 664, 818, 803 & 804 Compliant

## OUTLINE DRAWING

Cable Length Options

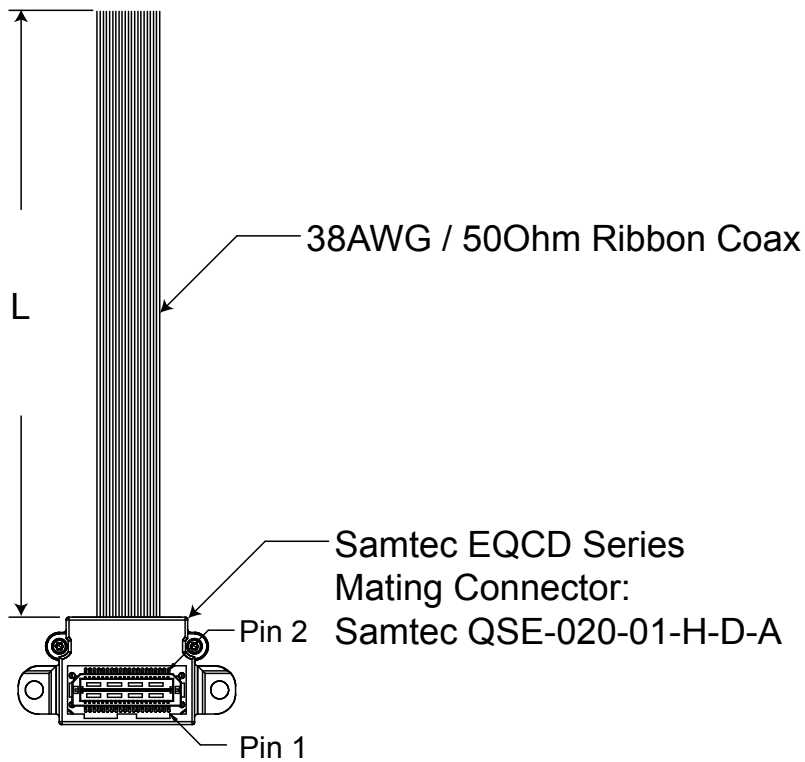

### Ribbon Coax Cable Length Options

L (mm) +/- 6.0	ITEM #
50	xxxx-xxxx-xx-L050
100	xxxx-xxxx-xx-L100
150	xxxx-xxxx-xx-L150
200	xxxx-xxxx-xx-L200
250	xxxx-xxxx-xx-L250



# Facilitating Secure Communications in Harsh Environments

Cobra Series D38999/11-35 Active Optoelectronic Cable Adapter,  
Multimode, 850nm, ARINC 664, 818, 803 & 804 Compliant

## PRINTED CIRCUIT BOARD FOOTPRINT

All dimensions shown are for reference only: inches [mm]

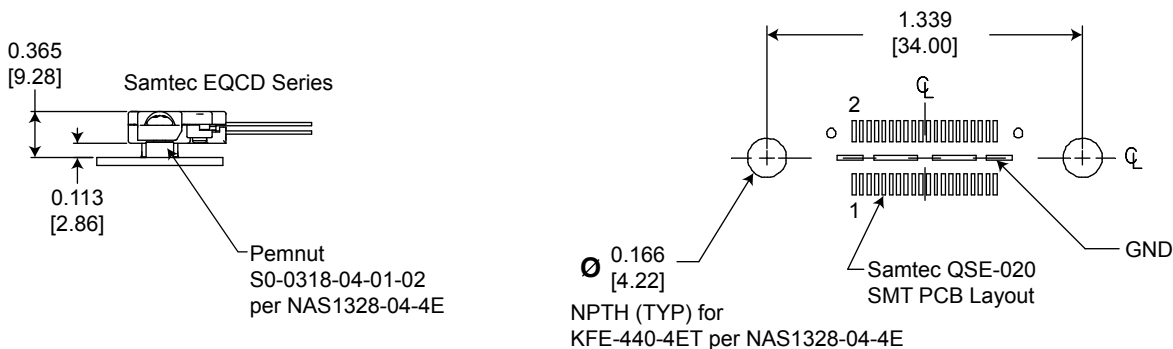

## SAMTEC EQCD PIN ASSIGNMENTS

ELECTRICAL		
PIN #	FUNCTION	LOGIC FAMILY
1	LOS	Open Drain CMOS
2	GND	N/A
3	RX-	CML
4	NC	N/A
5	RX+	CML
6	TX_DIS	CMOS
7	TX-	CML
8	V <sub>CC</sub>	3.135 to 3.465VDC
9	TX+	CML
10	V <sub>CC</sub>	3.135 to 3.465VDC
11		
12		
13		
14		
15	NC	N/A
16		
17		
18		
19		
20	V <sub>CC</sub>	3.135 to 3.465VDC

Center slug is Ground.

For the Transmit Disable (TX\_DIS) Functions: Logic 1: Disable Optical Output, Logic 0: Enable Optical Output

For the Loss of Signal (LOS) Functions: Satisfactory Optical Input: Logic "0" Output, Unsatisfactory Optical Input: Logic "1" Output

All CML functions are internally AC coupled with 100Ω differential termination.

All other pins are NC.

Cobra Series D38999/11-35 Active Optoelectronic Cable Adapter,  
Multimode, 850nm, ARINC 664, 818, 803 & 804 Compliant

## APPLICATION SCHEMATIC For Xilinx Rocket I/O Interfaces

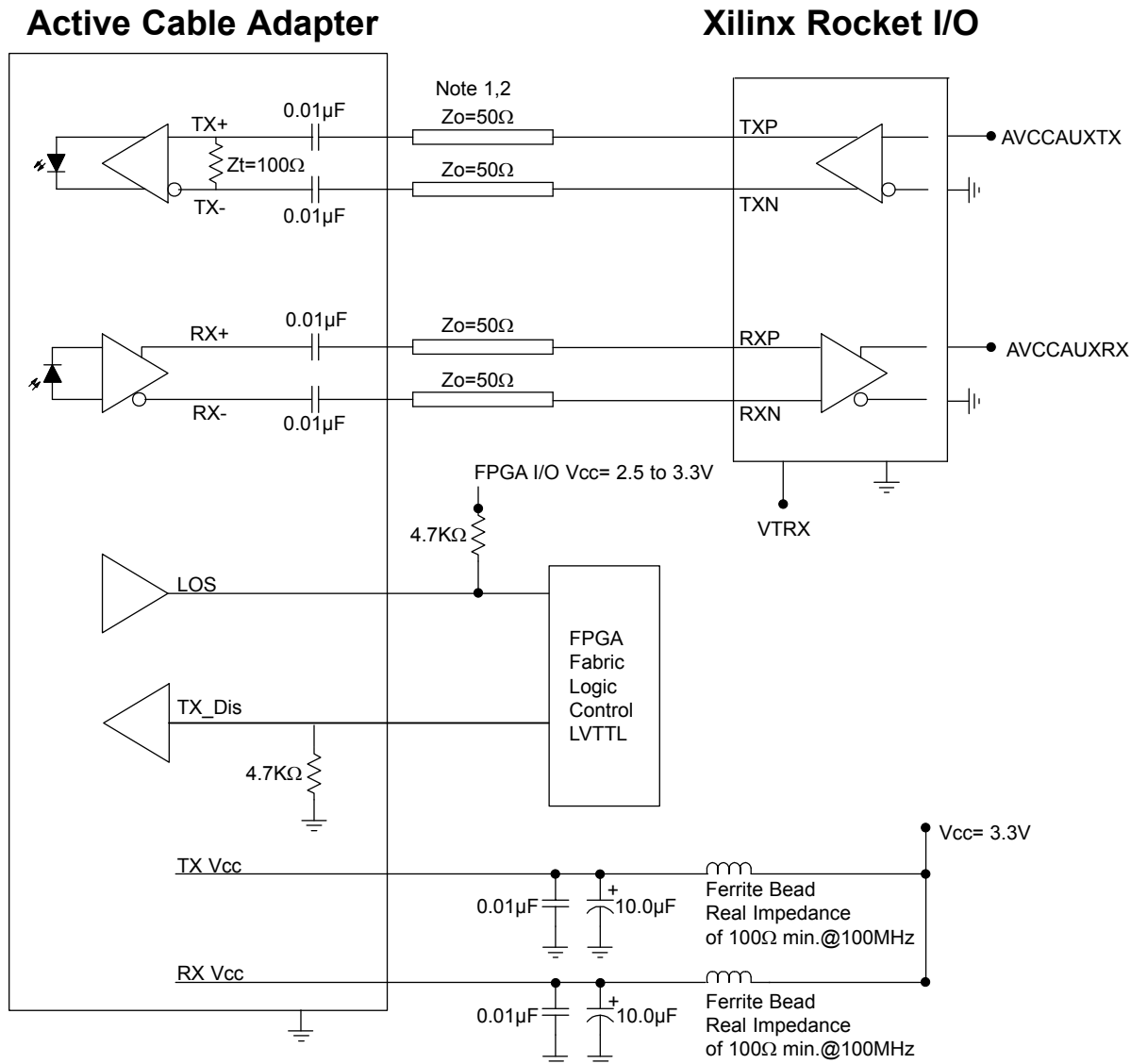

Typical application schematic shown  
For alternate applications or termination  
techniques, please consult the Factory

Note: 1  
When using controlled impedance cable  
(Coaxial cable) and Pre\_Emphasis,  
lengths of 1.0meter are obtainable.

Note: 2  
50 Ohm impedance termination shown.  
For alternate impedance requirements,  
please consult the Factory.

All Protokraft statements, technical information and recommendations related to the products herein are based upon information believed to be reliable or accurate. However, the accuracy or completeness thereof is not guaranteed, and Protokraft assumes no responsibility for any inaccuracies. The user assumes all risks and liability whatsoever in connection with the use of a product or its application. Protokraft reserves the right to change at any time, without prior or subsequent notice, the design, specifications, function, fit or form of its products described herein, including withdrawal at any time of a product offered for sale herein. Protokraft makes no representations that the products herein are free from any intellectual property claims of others. Protokraft and the Protokraft logo are trademarks of Protokraft, LLC. Other trademarks are the property of their respective holders. Contact Protokraft for prices and availability. For the most recent version of this data sheet, please go to the Protokraft website at <http://www.protokraft.com>. In case of discrepancy, the web version takes precedence over any printed literature. ©2004 Protokraft, LLC. All rights reserved.

Cobra Series D38999/11-35 Active Optoelectronic Cable Adapter,  
Multimode, 850nm, ARINC 664, 818, 803 & 804 Compliant

## APPENDIX A1 PART NUMBER OPTIONS

Cobra Series 11-35

**C35P - 2S1E - Bx - L**

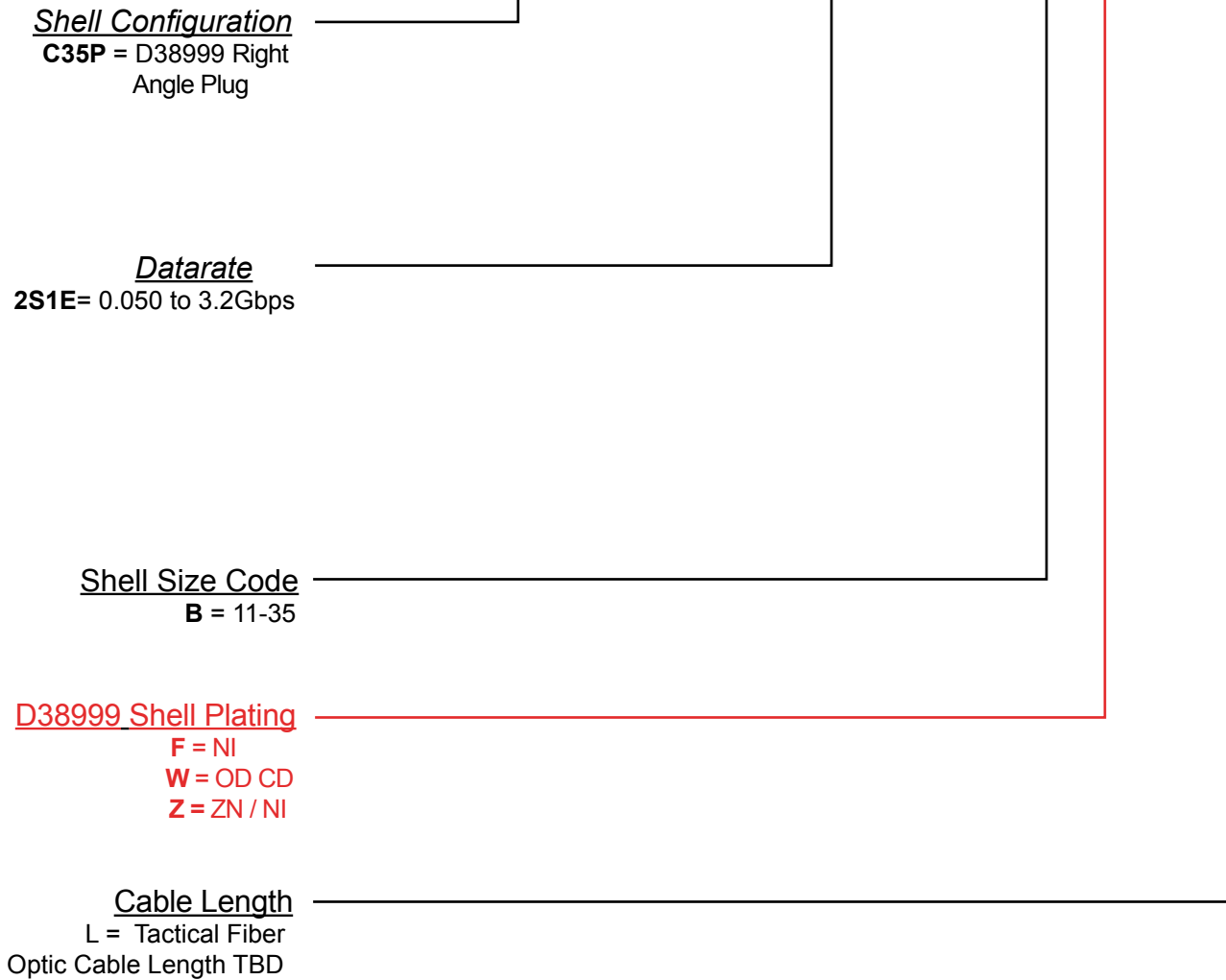

Other wavelength, mounting and port count options are available.  
Please consult the Protokraft website for alternate configurations.

# Facilitating Secure Communications in Harsh Environments

Cobra Series D38999/11-35 Active Optoelectronic Cable Adapter,  
Multimode, 850nm, ARINC 664, 818, 803 & 804 Compliant

## APPENDIX A2 PART NUMBER OPTIONS

Thunder Series D38999/11-35 Ribbon Coax to Samtec SMT Cable Assembly

**C38** **X** - **3513** - **B** **X** **X** - **L**

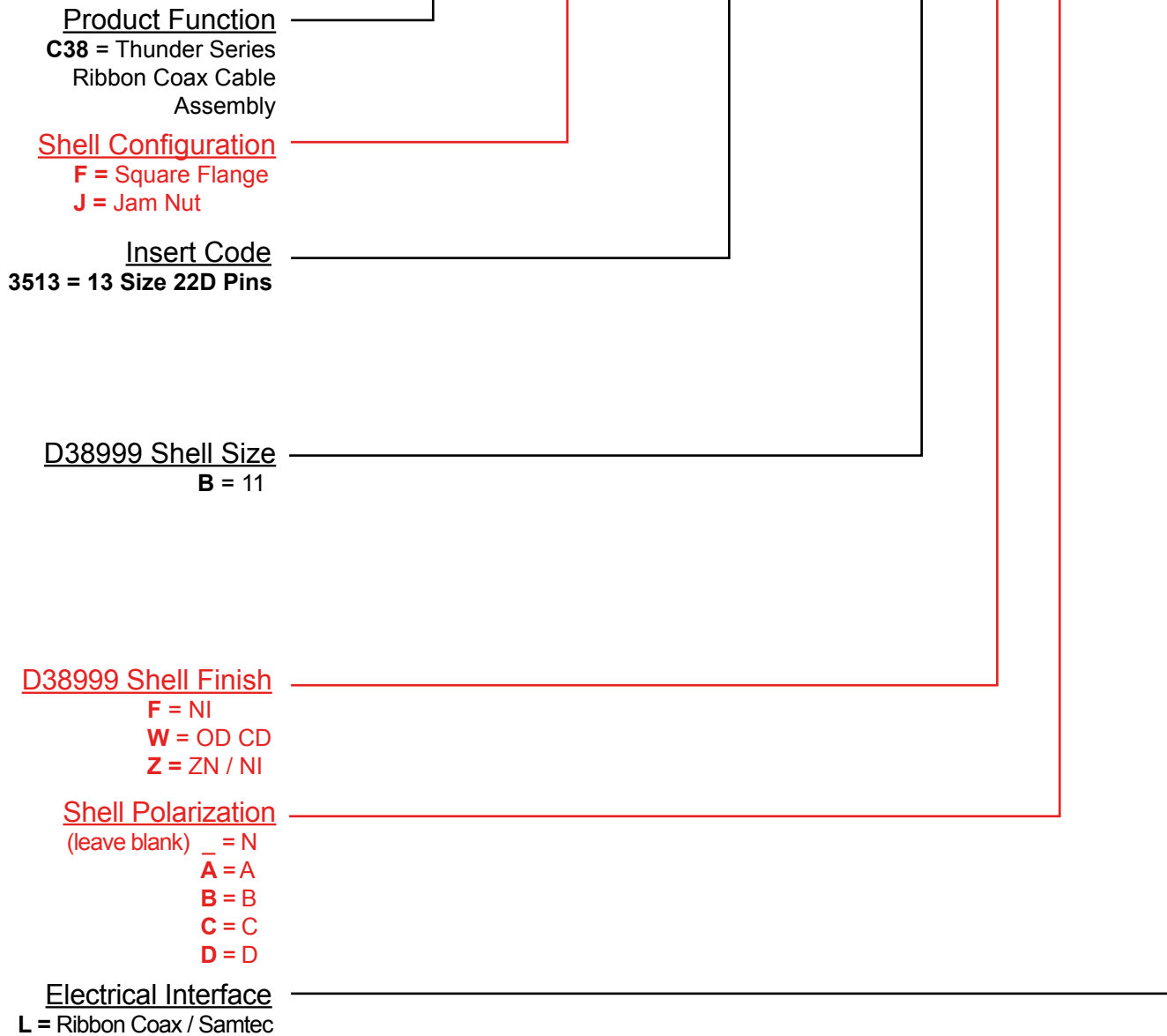

Other mounting and interface options are available.  
Please consult the Protokraft website for alternate configurations.